

Protecting an SMS Sender ID



Contents

1	Introduction	2
2	Text message scams are a significant problem.....	2
3	Measures for preventing spoofing	4
4	How to protect an SMS Sender ID.....	4
4.1	What kind of SMS Sender IDs can be protected?.....	5
4.2	Registering an SMS Sender ID.....	7
4.3	Traficom charges an annual fee for the use of an SMS Sender ID.....	7
4.4	A registered SMS Sender ID is adopted within 3 calendar months	7
4.5	Traficom informs telecommunications operators about new SMS Sender IDs	8
4.6	Telecommunications operators' measures concerning protected SMS Sender IDs.....	8
4.7	The SMS number associated with a protected ID	8
5	Processing of SMS Sender IDs in communications networks	9
6	Relevant regulations.....	10

1 Introduction

Scams involving impersonation and the spoofing of text message sender information (SMS Sender ID) have been a major problem, with most Finnish mobile phone users having received spoofed text messages at one time or another.

To reduce scams, Finnish Transport and Communications Agency Traficom (hereinafter Traficom) has issued a regulation that limits criminals' chances of spoofing the SMS Sender ID that is visible to the recipient of the text message.

The regulation requires that organisations sending SMS messages to Finnish recipients must have approval for all sender IDs they use in advance. This can be done either by authorizing the sender IDs to be used through your own SMS service provider ([Sender ID Code of Conduct](#)) or, if the sender specifically needs to have exclusivity to a specific SMS Sender ID, it can protect the alphanumeric SMS Sender ID it uses in Traficom's service in accordance with this instruction.

Traficom recommends that all organisations review their need to protect their SMS Sender IDs- is the exclusivity a must or can organisation instead use less strict authorisation process. Applications for registering SMS Sender IDs can be submitted using an application form available on Traficom's website. More detailed instructions for the application process are provided below under section 4 Protecting SMS Sender IDs.

This document provides a description of how the sending of text messages is administered in the application programming interface (API) to prevent SMS Sender ID spoofing. Furthermore, this document includes Traficom's instructions on how to protect SMS Sender IDs in Finland. The described model was prepared by a Traficom working group in collaboration with Finnish telecommunications companies in 2022–2023.

2 Text message scams are a significant problem

SMS Sender ID spoofing is an international phenomenon that also plays a major role in internet fraud perpetrated in Finland.

The reason behind the phenomenon is the fact that text messages are a very easy way for criminals to reach potential victims. This is apparent when looking at the numbers of spoofed messages sent under the name of banks and various logistics companies in particular. For example, bank customers often do not understand that familiar SMS message chains in their phone can contain messages sent by criminals that include phishing links. Clicking these links takes the customer to a phishing site run by criminals instead of their online bank service, and if the customer enters their bank credentials on the phishing site, they may end up losing their money. Criminals can also use a familiar and official-looking SMS Sender ID to trick their victims into believing that a message is from a familiar public authority or other organisation. Below are some examples of what such scam messages can look like:

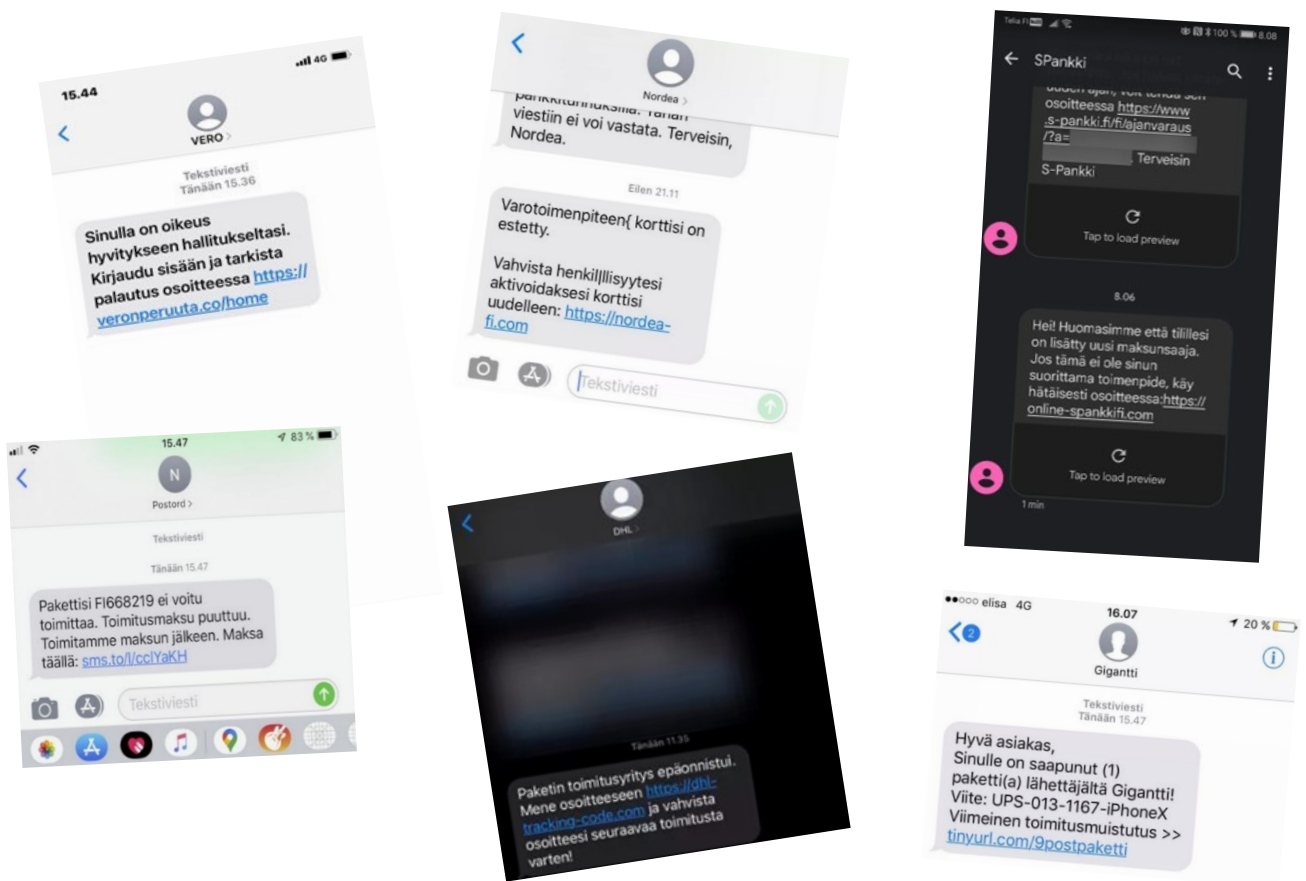

The prevalence of SMS Sender ID spoofing is also apparent from the numbers of incidents reported to the police that involve the victim losing money from their bank account. In many cases, the victim does not fully understand what has happened when they file the police report. These types of fraud are filed under means of payment fraud, for example, which have increased by over 50% between 2021 and 2022. Based on statistics published by Finland's National Bureau of Investigation (NBI), in June–August 2022 alone, there were approximately 750 recorded cases of fraud involving criminals impersonating banks in Finland, resulting in approximately EUR 2.5 million in criminal proceeds. Of these cases, 600 involved text messages sent in a bank's name.

Traficom's recommendation is that all organisations that send text messages containing alphanumeric SMS Sender IDs to citizens should protect their SMS Sender IDs.

Traficom recommends that all organisations that send text messages containing alphanumeric SMS Sender IDs to citizens pay attention to how the messages are distributed to Finnish mobile phone users. There are numerous service providers in Finland, including network operators, that distribute large amounts of identical text messages or text messages related to the same service from applications to mobile phones. These types of companies are generally called SMS aggregators.

There are also foreign SMS aggregators that are able to provide reliable, contract-based services in Finland. One of the requirements for protecting SMS Sender IDs is that the messages are sent via an API of a mobile network operator operating in Finland. When using some other kind of connection, protecting a SMS Sender ID is not possible.

3 Measures for preventing spoofing

In 2022, Traficom intervened in caller ID spoofing with excellent results. According to the NBI's estimate, in 2020 and 2021, Finnish people lost approximately EUR 7.1 million to technical support scam calls alone. However, in 2022, following national measures implemented by telecommunications operators and authorities, the criminal proceeds from scam calls fell to just EUR 600.

Traficom's regulation update also made SMS spoofing more difficult. As a result of the regulation, it is no longer possible to send from abroad a text message to a Finnish recipient with a sender information containing a short message service number or a number starting with +358, the country code of Finland.

According to the SMS standard, the sender information, or 'from' field, of a text message does not necessarily need to be the sender's mobile phone number, such as 040 1234567, as it can also be an alphanumeric string including in maximum 11 characters. This alphanumeric string is called the SMS Sender ID.

As a result of the updated Traficom regulation M28 in 2023, organisations sending text messages via an API have been able protect their SMS Sender IDs under certain conditions (see section 4 below). Once a SMS Sender ID is protected, only the party that registered the SMS Sender ID will be able to use it in Finland.

SMS Sender IDs are widely used by both businesses, such as banks and logistics companies, and public sector organisations. Various public authorities also use SMS Sender IDs when sending out text messages. For example, the Ministry of Social Affairs and Health used the SMS Sender ID 'Tiedote' ('Bulletin') when communicating about the COVID-19 situation. In this case, it would have been relatively easy for a scammer to use the same SMS Sender ID to deceive recipients. One concrete example of the problem are scam text messages sent under the name of the Finnish Tax Administration.

The updated regulation in May 2026 made it compulsory for organizations that send text messages to Finnish recipients to get approval in advance for all the sender IDs they use. The organization sending text messages can now as an alternative to protection choose authorization process instead. Authorization is based on the common process defined by the industry. This document describes only the protection service provided by Traficom.

4 How to protect an SMS Sender ID

Traficom has created a model for protecting SMS Sender IDs and verifying that they are unambiguous and genuine. As a result, organisations that send out text messages can now protect their SMS Sender IDs, provided that certain conditions are met. The process is described in sections 4.1 - 4.7 below.

The model allows parties that send text messages to citizens to protect their SMS Sender IDs and ensure that no other party can use the same alphanumeric SMS Sender IDs when sending messages to Finnish mobile phone numbers. Once Traficom has registered an SMS Sender ID to be protected, there is a three-month transition period. After the transition period, the SMS Sender ID can only be used by the party that registered it. Text messages sent by any other parties using the protected SMS Sender ID will not be forwarded to a Finnish subscriber.

In connection with the registration of an SMS Sender ID, Traficom issues a Short Message Service number beginning with 19 to the applicant, which is used for traffic control and identification in the operator API. This SMS number is not visible to end users, and the applicant should not disclose it to the public!

4.1 What kind of SMS Sender IDs can be protected?

In order for an organisation to protect an SMS Sender ID and secure exclusive usage rights to it, the SMS Sender ID must be **exactly the same** as one of the following names of the organisation as recorded in Finland's Business Information System (YTJ):

- i) company name
- ii) auxiliary company name or
- iii) parallel company name.

The SMS Sender ID to be protected must also meet the format requirements of the standard, meaning that it can be in maximum 11 characters long and must follow the 3GPP specification TS23.038¹ (GSM 7 bit default alphabet).

Concerning special characters, including scandinavian letters å, ä or ö, the requesting organisation should check with their service provider to see if the SMS Sender ID works as intended in the planned use case. This verification should be made before the application for registration of the SMS Sender ID. In some cases, the protocol of the application interface of the Short Message Service Centre supports a character set that is narrower than the standard also in Finland, and the internationally compatible character set is even narrower. When used internationally, SMS Sender ID should contain only the following characters: 0–9, a–z, A–Z and space.

It should also be noted that an SMS Sender ID cannot begin or end with a space or contain multiple consecutive spaces. This is because recipients have no practical means of distinguishing such SMS Sender IDs, which could potentially be exploited for malicious purposes.

When the company name, auxiliary company name or parallel company name includes one or more spaces or a hyphen, those can be omitted when registering an SMS Sender ID. In addition, in the SMS Sender ID to be protected, 'a' may replace the character 'å' or 'ä', and 'o' may replace the character 'ö' if these characters appear in the company name, auxiliary company name or parallel company name on which the application is based. However, it is not possible to apply for such a version that already is a company name, auxiliary company name or parallel company name of another organisation.

Applicants can register the SMS Sender ID using lowercase and/or uppercase letters. For example, if the applicant's auxiliary company name is OmaYritytys, it can apply for protection for such names as OmaYritytys, omayritytys, Omayritytys, etc. It is intended that registration is applied for only one form of writing.

When Traficom registers an SMS Sender ID, the protection provided by the registration covers automatically all lettersize variations of the specific SMS Sender ID.

Since company names are unique even without indications of corporate form, Traficom can register a company name and a parallel company name for use as an SMS Sender ID without the indication of corporate form as well. For example, if the applicant's company name is 'Oy Yritytys Ab', they could also protect the SMS

¹ <https://www.3gpp.org/specifications-technologies/specifications-by-series>

Sender ID 'Yritys'. Indications of corporate form are listed at <https://www.prh.fi/en/kaupparekisteri/yritystennimet/nimiohjeet.html>

When applying for the protection of their company name or parallel company name, the applicant can thus leave out the following indications of corporate form from their SMS Sender ID:

- Asunto Oy or As Oy
- Tmi or Toiminimi
- Osakeyhtiö or Oy
- Julkinen osakeyhtiö or Oyj
- Kommandiittiyhtiö or Ky
- Avoin yhtiö
- Osuuskunta, yhdysosa osuus or osk
- sivuliike Suomessa, Suomen sivuliike, filial i Finland or filial
- Ab, Abp, AS, GmbH, Inc, Ltd, UAB or OÜ (with or without a period)

If the applicant wishes to protect an SMS Sender ID that has not been registered with the Finnish Patent and Registration Office (PRH) by a previous applicant, they can do so quite affordably by registering it as an auxiliary company name, for example (EUR 60.00/name at the time of writing this document).

PRH's more detailed instructions for the registration of auxiliary company names are available here: <https://www.prh.fi/en/kaupparekisteri/yritysten-nimet/aputoiminimi.html>

It should be noted that bodies governed by public law and associations are in principle not among the entities that must be entered in the Trade Register and thus cannot register company names, meaning that they cannot register SMS Sender IDs based on company names either. If the association is also registered in the Trade Register in addition to the Association Register and the association has an appropriate business name in the Trade Register, the association can apply for an SMS Sender ID. When submitting the request, the applicant may omit the association indicator ry from the end of the requested SMS Sender ID.

Protecting the IDs of bodies governed by public law

Bodies governed by public law can protect other IDs, however. The ID to be protected must still be unique, in addition to which it cannot be a company name registered by another entity or a common word unrelated to public sector operations, such as 'tiedote' ('bulletin') or 'huolto' ('maintenance').

Furthermore, the applicant under public law must prove that it has the 'right of possession' to the name in Finland. This means that the organisation's own name or identifier is usually the clearest option to use as the SMS Sender ID to be registered. If the SMS Sender ID to be registered is a common word describing public sector operations, this can often be considered to fall within the purview of central government, meaning that a regional organisation cannot register such an SMS Sender ID. An internet domain name held and actively used by an organization can also often be a good choice as an SMS Sender ID for an applicant under public law.

4.2 Protecting an SMS Sender ID

An organisation sending text messages can apply for the protection of an SMS Sender ID by filling out the application form available on Traficom's website at <https://www.traficom.fi/en/services/apply-short-message-service-sms-sender-id>

The application must include the following information:

- name of the company or organisation
- business ID
- VAT ID
- postal and invoicing addresses
- name and email of contact person
- the SMS Sender ID for which registration is requested

The applicant can also include additional information in the additional information field of the form.

The applicant can also issue a power of attorney to a service provider that they use (telecommunications operator or aggregator) and ask them to handle the registration of an SMS Sender ID on applicant's behalf.

Traficom will register the SMS Sender ID to be protected only if it is **exactly the same as the organisation's company name, auxiliary company name or parallel company name**. For more detailed registration criteria and information on the registration of SMS Sender IDs by bodies governed by public law and indications of corporate form, please see section 4.1 above.

Traficom will, provided that the conditions detailed above are met, issue the applicant an SMS number beginning with 19 and register the requested SMS Sender ID to the applicant. The issuing of the SMS number also serves as a so-called registration decision.

Registered SMS Sender IDs and their registration dates and users are listed on Traficom's website at <https://traficom.fi/en/registered-sms-sender-ids>

4.3 Traficom charges an annual fee for the use of an SMS Sender ID

Basing on the Ministry of Transport and Communications' decree on transport service fees², the **annual fee** charged by Traficom for the registration of one SMS Sender ID is **EUR 200**. The fee will be charged to the registering organisation in two annual instalments.

4.4 A registered SMS Sender ID is adopted within 3 calendar months

A registered SMS Sender ID must be adopted in the Finnish telecommunications network within 3 months of Traficom's registration decision. For this, the organisation that registered the SMS Sender ID must enter into an agreement on the use of the ID with one or more telecommunications operators or SMS aggregators offering services in Finland.

After the 3 months, the registered ID can no longer be used to send text messages to Finnish mobile phone users except in the manner described above via agreed upon routes and all other traffic using the same ID will be blocked (for more details, please see section 4.6 below).

² [Liikenne- ja viestintäministeriön asetus \(1190/2023\)](#) Liikenne- ja viestintäviraston sähköiseen viestintään liittyvistä suoritteista perittävistä maksuista

4.5 Traficom informs telecommunications operators about new SMS Sender IDs

Following the same procedure as used with numbering decisions, Traficom will inform all telecommunications operators exchanging SMS traffic in Finland about the registration of SMS Sender IDs to organisations. Registered SMS Sender IDs are also listed on Traficom's website.

4.6 Telecommunications operators' measures concerning protected SMS Sender IDs

Every telecommunications operator exchanging SMS traffic in Finland must carry out the following measures within 3 calendar months of the registration decision:

- a) The telecommunications operator must block all SMS traffic using the registered SMS Sender ID from international gateways and APIs.
- b) Based on an agreement with the SMS provider that registered the ID, the telecommunications operator configures the API to allow SMS traffic using the registered SMS Sender ID only from that SMS provider.

This means that e.g. if the ID was registered on 15 November 2023, the ID must be blocked on 15 February 2024. If the blocking date falls on a weekend or public holiday, the blocking can be implemented on the following business day. Telecommunications operators can also implement the blocking in their own networks before the three calendar months have passed, provided that they have agreed to do so with the organisation that registered the ID.

Protecting an SMS Sender ID does not affect national SMS traffic between telecommunications operators, and messages will still be transmitted from one operator to the next as before. This makes it possible for a SMS service provider to enter into an agreement with one or more telecommunications operators or aggregators, if they so choose.

4.7 The SMS number associated with a protected ID

In connection with the registration of an SMS Sender ID, the applicant is issued an SMS number beginning with 19, based on which the associated SMS Sender ID can always be identified in the SMS traffic of Finnish mobile networks. The SMS number is a technical identifier that a telecommunications operator can use to identify traffic from the right sender. This SMS number is only used between the organisation that protected the associated SMS Sender ID and the telecommunications operator(s) exchanging SMS traffic, and it is not visible to the users of the service. As such, the SMS number should not be publicly disclosed.

5 Processing of SMS Sender IDs in communications networks

As illustrated in the figure below, using a protected SMS Sender ID as the “from” information of a text message is only possible when the text message is exchanged via a Finnish telecommunications operator’s SMS API that has been specifically configured to allow traffic using the ID. To this end the organisation sending text messages (such as a bank, insurance company or care enterprise) must enter into an agreement with at least one Finnish telecommunications operator directly or via an SMS aggregator that the organisation uses.

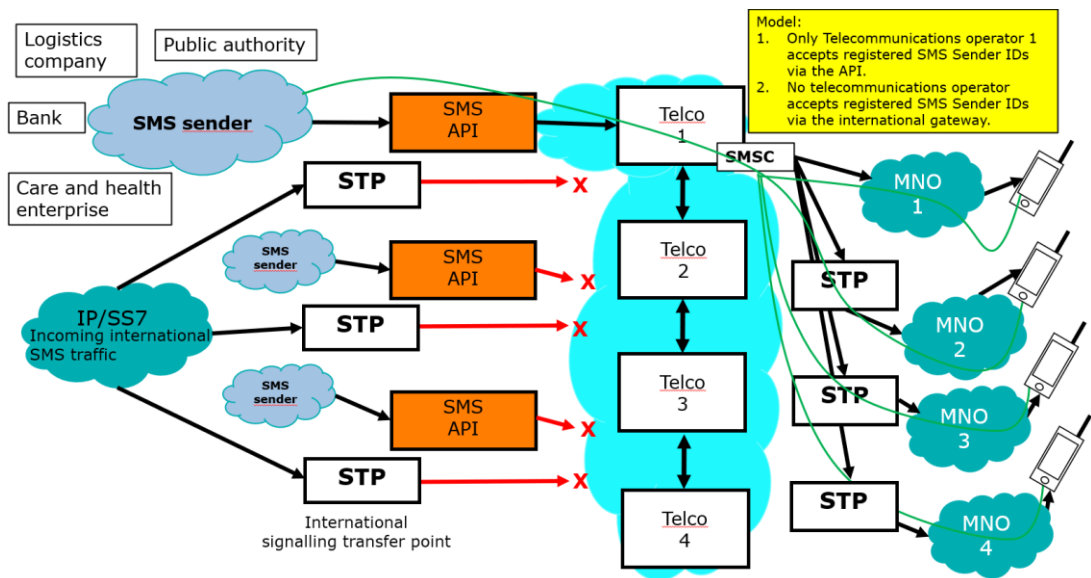

In the example situation depicted in the figure, the organisation sending text messages has entered into an agreement with Telecommunications operator 1. Therefore Telecommunications operator 1 accepts SMS traffic that uses a protected SMS Sender ID registered to the organisation sending text messages as the sender name.

Telecommunications operator 1 can deliver such a text message to its own mobile subscribers in mobile network MNO 1, or alternatively forward such a text message via national interconnect to the mobile subscribers of other telecommunications operators in Finland, i.e. mobile networks MNO 2, MNO 3 and MNO 4 in the figure.

Any text messages using an SMS Sender ID registered to an organisation that arrive via international gateways must be blocked in accordance with the figure.

Telecommunications operators can also block text messages using so-called blacklisted SMS Sender IDs in various APIs.³ Blacklisted SMS Sender IDs are variants of an SMS service provider’s company name, auxiliary company name or parallel company name that could be used for means of payment fraud, for example.

³ If this requires the processing of traffic data, the blocking must be carried out in accordance with section 272 of [the Act on Electronic Communications Services \(917/2014\)](#).

Summary – Grounds for blocking SMS Sender IDs in communications networks:

- 1) The SMS Sender ID is protected.
- 2) Blocking based on the request of an organisation that has registered an SMS Sender ID (such as a bank) in accordance with section 272 of the Act on Electronic Communications Services (917/2014). This is carried out with agreements between the organisation and telecommunications operators.
- 3) To prevent an information security threat detected by a telecommunications operator.
- 4) Based on a notification issued by Traficom due to a detected information security threat.

6 Relevant regulations

Traficom regulation 28 on the interoperability of communications networks and services

Regulation 28 concerns the interconnectivity and interoperability of public communications networks and public authority networks, including the communications services provided therein. The regulation also lays down provisions on signalling, timers, tones, announcements and ringing signals of communications services provided by the telephone network, and transfer of subscriber's number information in communications networks.

The regulation ensures the functioning and correctness of the telephone network and subscription number exchange and the correctness of message sender information and includes relevant obligations imposed on telecommunications operators.

<https://www.traficom.fi/en/communications/communications-networks/technical-operability-telecommunications>

Traficom regulation 32 on numbering in a public telephone network

The regulation lays down provisions on numbers and identifiers in communications networks. The services provided in communications networks require unambiguous numbering. This regulation includes Finland's national numbering plan and number selection charts. In addition to this, the regulation defines identifiers necessary for the technical interoperability of communications networks.

The regulation defines Short Message Service numbers beginning with 19 to support the registration of alphanumeric SMS Sender IDs.

<https://www.traficom.fi/en/communications/broadband-and-telephone/telephone-network-numbering>

Finnish Transport and Communications Agency

Traficom

PO Box 320, FI-00059 TRAFICOM, Finland

tel. +358 29 534 5000

traficom.fi

TRAFICOM
Finnish Transport and Communications Agency