

Scania-jarrujen tarkastuksessa huomioitavaa  
versio 3.5**Muutoshistoria**

<b>PVM</b>	<b>Lisätty</b>
23.02.2022	LPGRS-sarjan jarruliitinkaavio, Havahtumispainealaraja, Nouseva ja irti kytkeytyvä teliveto jarrudynamometrillä
24.11.2022	Teliveto ilman keskitauspyörästä ja tukiakselin nostotoimintoa

Tässä dokumentissa on kerätty tietoa Scania-kuorma- ja linja-autojen jarrujärjestelmistä.

**RUMPUJARRU**

ALB-venttiilin toiminnan ja säädön tarkastus teli alhaalla ohjauspaineella 6 bar, säätösuhde laskentaa varten teli ylhäällä.

PRTG-sarja (2004>) ALB toiminto sähköisesti ABS-järjestelmän kautta (ei erillistä venttiiliä eikä säätönomogrammia). Paikallaan oleva auto ei säädä jarrupainetta kuorman mukaan, joten ALB-säätösuhdetta ja kuormaamattoman ajoneuvon laskentaa ei voida suorittaa.

Järjestelmän toiminta on arvioitava auton oman diagnostiikan avulla.

Laskentapaineena voidaan käyttää arvoa 8,0 bar (katso tarkempi mallisarjakohtainen laskentapainearvosuositus alla olevasta taulukosta).

**LEVYJARRU**

EBS jarruilla varustettujen autojen ALB toiminto on sähköinen, joten ALB-säätösuhdetta ja kuormaamattoman ajoneuvon laskentaa ei voida suorittaa. EBS-järjestelmän toiminta on arvioitava auton oman diagnostiikan avulla.

Jarrutuspaineen syöttävät venttiilit ovat tietokoneohjattuja releventtiileitä, niiden sähköinen ohjaus voidaan ohittaa jättämällä virta-avain 0-asentoon. PR-sarjan (2004>) EBS aktivoituu myös virta-avaimen 0-asennossa, ohitus voidaan tehdä avaamalla akkujen pääkytkin.

Laskentapaineena voidaan käyttää arvoa 8,0 bar. Katso mittariston varoitustiedot tämän ohjeen lopussa.

**MÄKIJARRUTOIMINTO**

Mäkijarrutoiminto on lisävaruste EBS-järjestelmään, joka aktivoidaan erillisellä katkaisimella tarvittaessa.

**AJONVAKAUTUS ESP**

ESP on vakio/lisävaruste EBS-jarrullisiin ajoneuvoihin.

**LUISTONESTO TC**

TC estää vetävän pyörän luistamista rajoittamalla moottoritehoa ja jarruttamalla luistavaa pyörää.

TC off –kytkimellä voi ABS-järjestelmässä luistomäärää lisätä, mutta järjestelmää ei saa kokonaan kytkettyä pois. EBS-järjestelmässä TC off –kytkimen painaminen yli 5 sekunnin ajan kytkee TC ja ESP toiminnot pois.

**PERÄVAUNUN OHJAUSPAINEN ENNAKKO**

Ohjauspaineen nosto on tehdasasetuksena 0,3 bar, se on portaattomasti muutettavissa 0,8 tai 1,2 bar arvoon asti (Knorr,Wabco). EBS järjestelmän yhteydessä ennakko voi säätyä automaattisesti, tai se voidaan ohjelmoida kiinteäksi.

**Laskentapainetaulukko**

LASKENTAPAINETAULUKKO MALLISARJOITTAIN		
Mallisarja		Laskentapaine (bar)
3- ja 4-sarjan	KA	7
PRGT-sarja	KA	8
3-sarja	LA	7
4-sarja	LA	8
KNF-sarja	LA	8

Scania-jarrujen tarkastuksessa huomioitavaa  
versio 3.5

## 4-sarjan jarruliitinkaavio

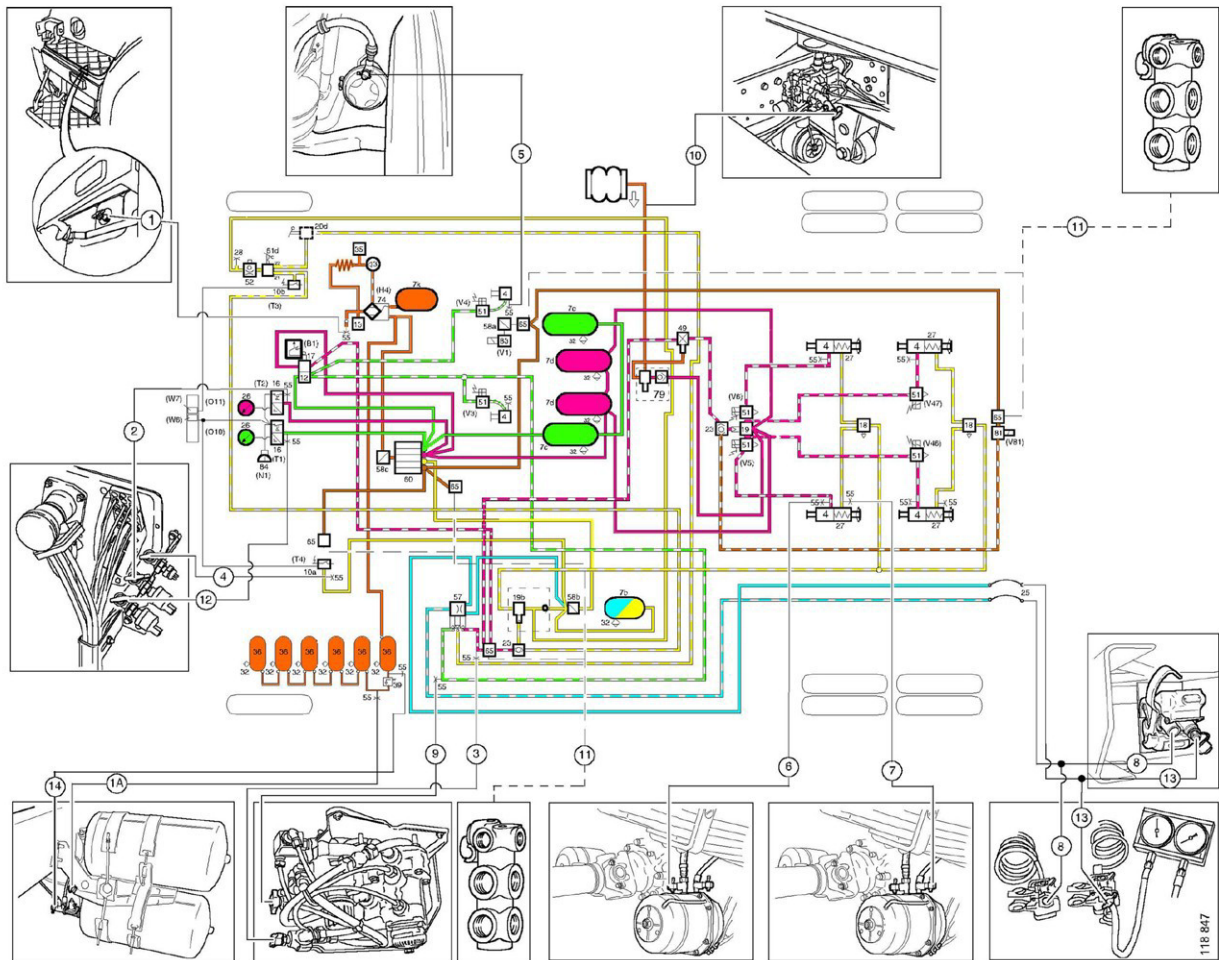

Scania-jarrujen tarkastuksessa huomioitavaa  
versio 3.5

PRG-sarjan jarruliitinkaavio

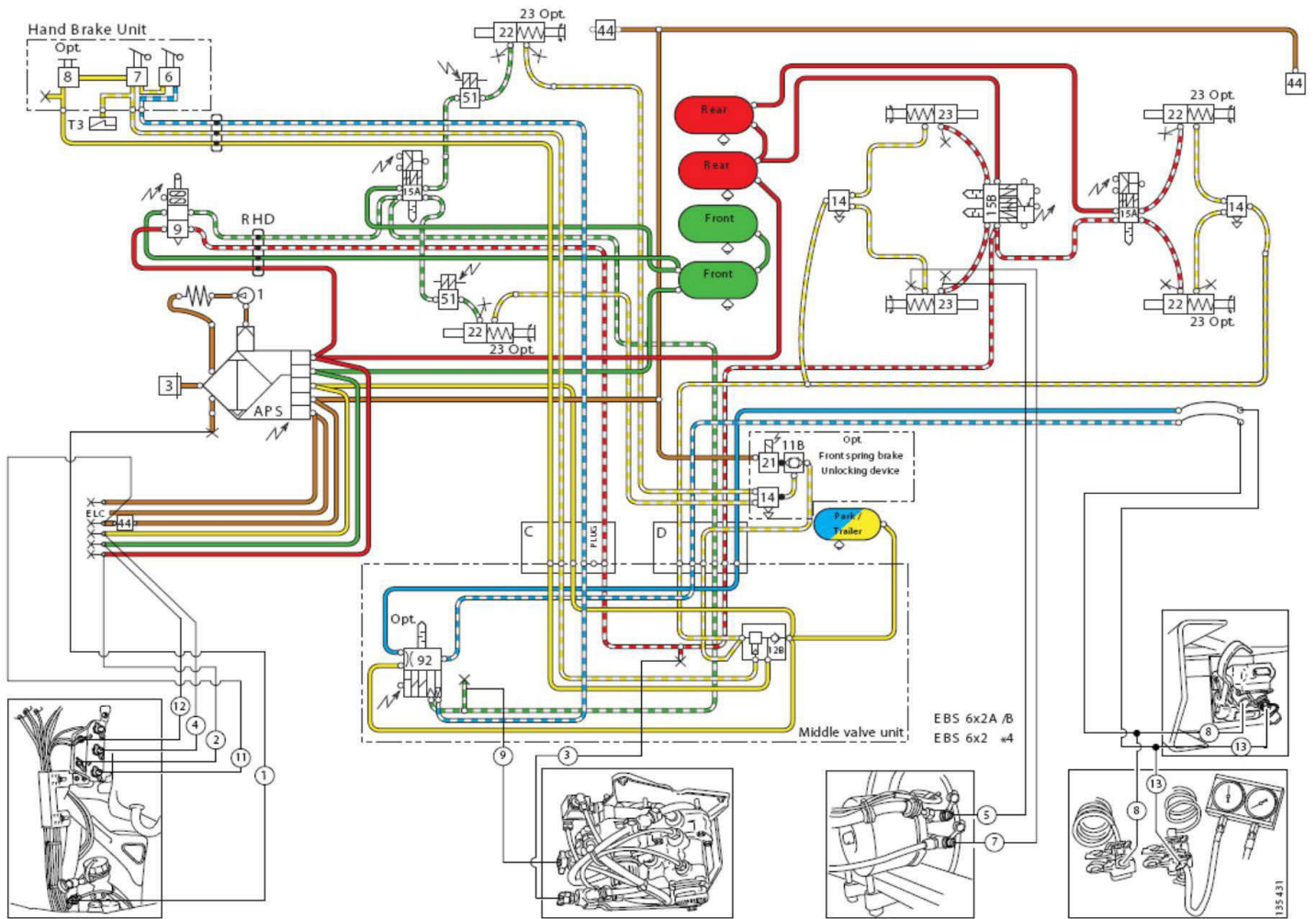

Scania-jarrujen tarkastuksessa huomioitavaa  
versio 3.5

L, P, G, R, S-sarjan jarruliitinkaavio

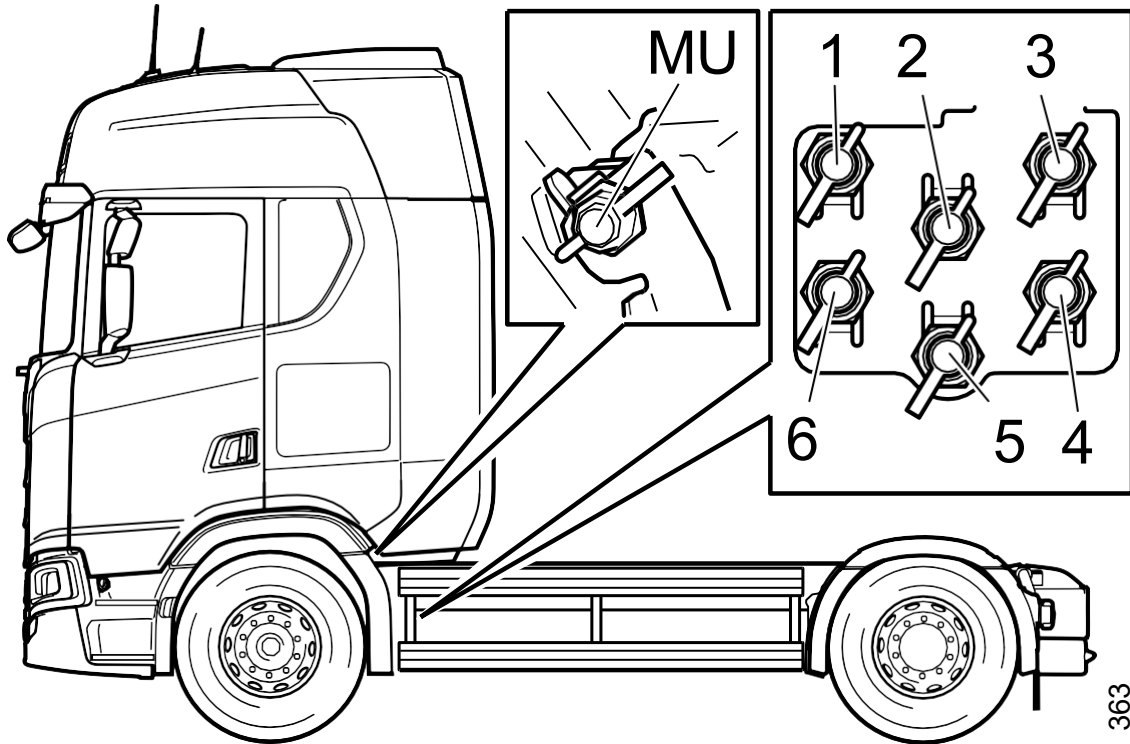

363

Mittausliitin		
1	Front 1	Jarrupaine 1. etuakselilla
2	Front 2	Jarrupaine 2. etuakselilla
3	Rear 1	Jarrupaine 1. taka-akselilla
4	Rear 2	Jarrupaine 2. taka-akselilla
5	Rear 3	Jarrupaine 3. taka-akselilla
6	Parking	Jarrupaine seisontajarrupiirissä
MU		Paineilman täyttö

**SCANIA-JARRUJEN TOOREETTINEN JARRUVOIMA**

Scania-jarrujen teoreettinen jarruvoima kN/akseli 8 baarin jarrupaineella. 15% poikkeamaa teoreettisesta jarruvoimasta voidaan pitää normaalina, suuremmat poikkeamat on tarkastettava tapauskohtaisesti. Laskennassa on renkaan säteenä käytetty STRO-rengasnormi- kirjan vierintäkehästä laskettua arvoa.

F	Force of brake chamber. See note *) and table below												
i	internal ratio including brake lever = 15.6												
C	Servo factor = 0.80												
D	Effective diameter of brake disc = 342 mm												
η	Mechanical efficiency = 0.9												
B	Dynamic tyre radius (mm)												
<p>Force from the brake chamber at <b>6.1 bar control pressure</b>.          (To compensate for the mechanical losses in the transmission, the <u>control</u> pressure must be reduced with 0.4 bar at all calculation of the chamber force "F")</p>													
	<table border="1"> <thead> <tr> <th>Brake chamber type</th> <th>Brake chamber force (N)</th> </tr> </thead> <tbody> <tr> <td>14</td> <td>4800</td> </tr> <tr> <td>16</td> <td>5750</td> </tr> <tr> <td>20</td> <td>6900</td> </tr> <tr> <td>24</td> <td>8200</td> </tr> <tr> <td>30</td> <td>11150</td> </tr> </tbody> </table>	Brake chamber type	Brake chamber force (N)	14	4800	16	5750	20	6900	24	8200	30	11150
Brake chamber type	Brake chamber force (N)												
14	4800												
16	5750												
20	6900												
24	8200												
30	11150												

**Levyjarrut**

$$\frac{F * i * C * D * \eta}{B}$$

Jarrukello	Akselin jarruvoima kN	Akselin jarruvoima kN
in2	295/80 R 22.5	315/80 R 22.5
24	61,0	59,2

Scania-jarrujen tarkastuksessa huomioitavaa  
versio 3.5

**RUMPUJARRUT**

$$\frac{F * L * C * D * \eta}{A * B}$$

F	Force of brake chamber, see table
L	Length of brake lever = 165 mm.
C	Servo factor = 1.90
D	Internal diameter of brake drum = 412.75 mm
$\eta$	Mechanical efficiency = 0.9
A	diameter of S-cam involute = 30 mm
B	Dynamic tyre radius (mm)
<p>Force from the brake chamber at <u>6.4 bar control pressure</u>. (To compensate for the mechanical losses in the transmission, the <u>control pressure</u> must be reduced with 0.4 bar at all calculation of the chamber force "F")</p>	
Brake chamber type	Force (N)
12	4000
16	5500
20	6500
24	8000
30	10750

Jarrukello/vipupituus in2/mm	Akselin jarruvoima kN 295/80 R 22.5	Akselin jarruvoima kN 315/80 R 22.5
16/130	30,1	30,0
16/165	39,3	38,1
20/165	46,4	45,1
24/165	57,1	55,5
30/165	76,8	74,6

### Mittariston varoitustiedot

EBS:n symbolit ja vikasanomat näytetään mittaristossa. Mahdolliset auton vikakoodit ovat myös luettavissa. Jos autoon on kytketty EBS-jarruilla varustettu perävaunu ja autoon kytketään virta, mittariston näyttö ilmoittaa 5 sekunnin ajan EBS-vikailmoitusta.

HUOM! Tämä ei merkitse vikaa, vaan tarkoituksena on ainoastaan varmistaa vikailmoitustoiminto. Merkkivalon jäädessä palamaan, on kyseessä järjestelmässä oleva vika.





## Linja-auton jarrujen dynamometrimittaus

Taustaa

Useimmat linja-autot ovat varustettu pysäkki- ja tai mäkkijarruvarustuksella, joka saattaa aiheuttaa hankaluuksia jarrujen dynamometrimittauksessa. Ohessa yleisohjeita eri bussiversioista, miten dynamometrimittaus voidaan suorittaa:

### Pysäkkijarrun vapauttaminen

- Erillisellä pysäkkijarrun passivointikatkaisijan avulla, jos sellainen katkaisija autosta löytyy

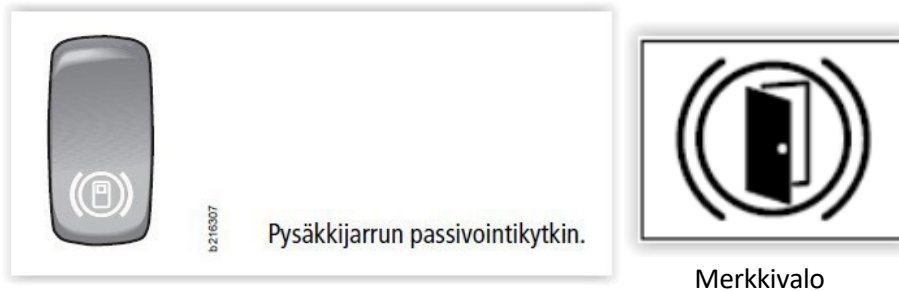

- sulkemalla ovet ja kuljettajapaikan portti
- autoissa, joissa on alkolukko, sen kytkentä on joissain tapauksissa tehty käynnistysvirtapiiriin sijasta pysäkkijarruun. Tällöin ensimmäinen liikkeellelähtö moottorin käynnistämisen jälkeen vaatii puhalluksen alkolukkoon pysäkkijarrujen vapauttamiseksi.

### Automaattisen mäkkijarrun vapauttaminen

- vaatii kaasupolkimen painalluksen

Yleisesti moottorin sammuttaminen ja päävirran katkaisu eliminoi kaikkien sähköisten jarrutoimintojen aktivoitumisen.

## Havahtumispainearaja sähkötoiminen jarrujärjestelmä

Traficomien määräyksessä TRAFI/15393/03.04.03.00/2015 on määritelty dynamometrimittauksessa havahtumispaineen ala- sekä yläraja (0,3-0,8 bar).

*Scanian EBS-jarrujen havahtumispainearaja voi olla 0,2 baaria ilman, että se tarkoittaa vikaa.*

## Nouseva ja irti kytkeytyvä teliveto jarrudynamometrillä

LPGRS-sarjan kuorma-autoihin on julkaistu nouseva ja irti kytkeytyvä teliveto (LDTA).

LDTA:lla varustetuissa autoissa ei ole pitkittäistä tasauspyörästöä akseleiden välillä vaan telissä on kiinteä vetoysteys telin akseleiden välillä. Taaempaa vetoakselia nostettaessa, veto ko. akselille katkaistaan. Kun molemmat vetoakselit ovat maassa, tilanne voidaan rinnastaa ristilukko päällä olevaan ns. tavalliseen telivetoon ja tämä aiheuttaa ongelmia esimerkiksi jarrudynamometritestillä, kun telin toiset vetävät pyörät ovat pitävällä alustalla ja toisia pyöritetään.

## TELIVEDON TYYPIN TUNNISTUS

Jotta voidaan määritellä, miten jarrudynamometritestin yhteydessä tulee menetellä, tulee ensimmäisenä tunnistaa, onko autossa ns. tavallinen teliveto vai nostettava ja irti kytkeytyvä teliveto LDTA. Tässä muutama vinkki, josta toiminnon voi tunnistaa:

1. Auton rekisteritiedoissa on merkitty telivetoisen telin 2. akseli nostettavaksi
2. Alla olevan kuvan mukaisesti nostomekanismin raudat taaemman vetoakselin yläpuolella sekä nostotoiminnon ilmapalkeet.

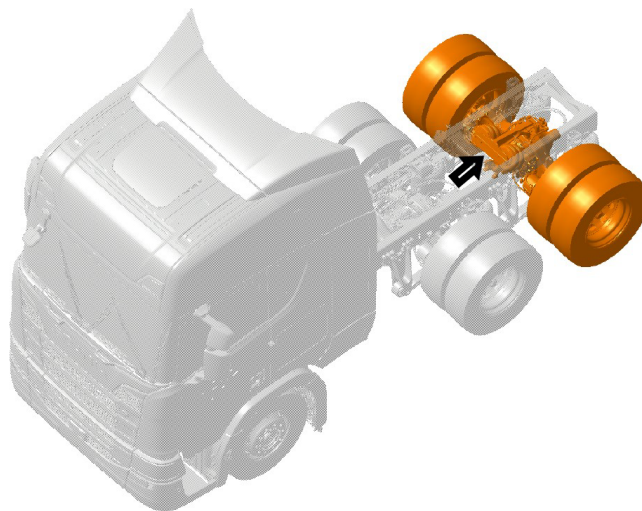

Scania-jarrujen tarkastuksessa huomioitavaa  
versio 3.5

3. Akselilukkojen käyttökattaisijavaihtoehdot



Yllä. 3 eri käyttökattaisijavaihtoehtoa

## Scania-jarrujen tarkastuksessa huomioitavaa versio 3.5

### Dynamometritilan kytkentä

Telin 2. akselin veto voidaan passivoida telin ollessa ala-asennossa kytkemällä teli dynamometritilaan seuraavasti:

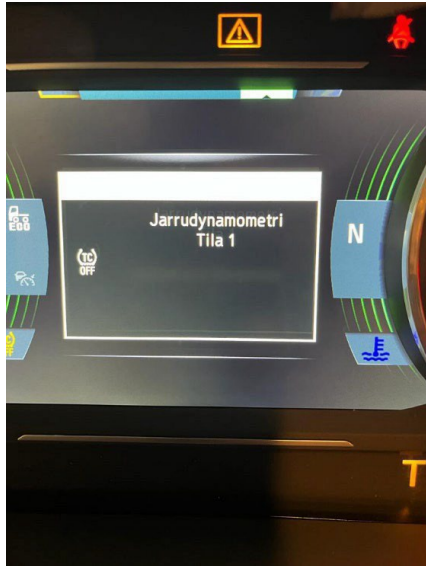

Vaativuksina dynamotilaan asettaessa 2. vetoakselin tulee olla laskettuna ja akselilukot lukitsematta.

Dynamometritila kytketään painamalla samanaikaisesti jarrupoljinta sekä TC- toiminnon kytkintä yli 6 sekuntia mutta alle 9 sekuntia.

TC-toiminto aktivoidaan kiertokytkimessä painamalla kiertokytkintä ja nappikytkimin varustetussa versiossa on erillinen TC-painokytin.

Dynamometritila passivoituu, kun TC-kytkintä painetaan lyhyesti tai kun ajoneuvon nopeus ylittää 10 km/h.

### Toimintajärjestys mitattaessa em. teliä

1. Mittaa ensin telin 1. akseli tukiakselin ollessa yläasennossa
2. Siirrä telin 1. akseli pois rullilta ja kytke dynamometritila ohjeen mukaisesti
3. Mittaa telin 2. akseli

### Teliveto ilman keskitauspöyrästä ja tukiakselin nostotoimintoa

Scaniale on valikoimassaan akseliperäinen telivetotyyppi, jossa ei ole pitkittäistä tasauspöyrästä akseleiden välillä eikä telin vetävän akselin nostotoimintoa.



Tunnistus

Lukkokatkaisijassa vain yksi toiminto ja vetävän akselin nostotoimintopainike puuttuu.

Tällöin telissä on aina kiinteä vetoyhteys telin akseleiden välillä. Dynamometritestissä on käytettävä apurullia tai vaihtoehtoisesti jarrut testattava jarrutuskokeella.

**HUOM!** Ajoneuvon muut akselit tulee kuitenkin tarkastaa dynamometrimittauksin.



# 10:03-53

Issue 2 en-GB

## Reference Brake Force for L, P, G, R, S Series



<b>General information</b> .....	4
Purpose .....	4
Instruction how to use the document.....	4
<b>EBS</b> .....	5
EBS Disc brake 4x2.....	5
EBS Disc brake 4x2.....	5
EBS Disc brake 6x2, 6x2*4, 6x2/2, 6x2/4.....	6
EBS Disc brake 6x2/2 MLA3.....	6
EBS Disc brake 6x4.....	7
EBS Disc brake 8x2, 8x2*6.....	7
EBS Disc brake 8x2/4, 8x2/*6 .....	8
EBS Disc brake 8x4*4.....	8
EBS Disc brake 8x4, 8x4/4 .....	9
EBS Disc brake 10x4*6.....	9
EBS Disc brake 10x4*6.....	10
EBS Drum brake 4x2.....	10
EBS Drum brake 4x2.....	11
EBS Drum brake 6x2Z .....	11
EBS Drum brake 6x2, 6x4.....	12
EBS Drum brake 6x4.....	12
EBS Drum brake 6x4.....	13
<b>ABS</b> .....	14
ABS Drum brake 4x2, 4x4 .....	14
ABS Drum brake 4x2, 4x4 .....	14
ABS Drum brake 4x2, 4x4 .....	15
ABS Drum brake 4x2, 4x4 .....	15
ABS Drum brake 6x2A/B, 6x4*4, 6x4, 6x6.....	16
ABS Drum brake 6x2A/B, 6x4*4, 6x4, 6x6.....	16
ABS Drum brake 6x2A/B, 6x4*4.....	17
ABS Drum brake 6x2A/B, 6x4*4.....	17
ABS Drum brake 6x2A/B, 6x4*4, 6x4, 6x6.....	18
ABS Drum brake 6x2A/B, 6x4*4, 6x4, 6x6.....	18
ABS Drum brake 6x2A/B, 6x4*4.....	19
ABS Drum brake 6x2A/B, 6x4*4.....	19
ABS Drum brake 6x4, 6x6 .....	20
ABS Drum brake 6x4, 6x6 .....	20
ABS Drum brake 6x4, 6x6 .....	21
ABS Drum brake 6x4, 6x6 .....	21
ABS Drum brake 6x2Z.....	22
ABS Drum brake 6x2Z.....	22
ABS Drum brake 6x2Z.....	23
ABS Drum brake 6x2Z.....	23
ABS Drum brake 8x2A/B, 8x4, 8x6, 8x8.....	24
ABS Drum brake 8x2A/B, 8x4, 8x6, 8x8.....	24
ABS Drum brake 8x2A/B .....	25
ABS Drum brake 8x2A/B, 8x4, 8x6, 8x8, 8x4/4.....	25
ABS Drum brake 8x2A/B, 8x4, 8x6, 8x8.....	26
ABS Drum brake 8x2A/B .....	26



---

ABS Drum brake 8x4, 8x6, 8x8, 8x4/4 .....	27
ABS Drum brake 8x4, 8x6, 8x8 .....	27
ABS Drum brake 8x4, 8x6, 8x8, 8x4/4 .....	28
ABS Drum brake 8x4, 8x6, 8x8 .....	28
ABS Drum brake 8x2Z.....	29
ABS Drum brake 8x2Z.....	29
ABS Drum brake 8x2Z.....	30
ABS Drum brake 8x2Z.....	30
ABS Drum brake 8x4*4 .....	31
ABS Drum brake 10x4*6 .....	31
ABS Drum brake 10x4*6 .....	32
ABS Drum brake 10x4*6 .....	32



# General information

## Purpose

The tables in this document should be used together with a roller brake tester. The values in the tables determine if the axle brake force is enough to achieve the legal requirements described in ECE R.13, §5.1.4.6.

## Instruction how to use the document

Find the correct vehicle type with the corresponding maximum technical GVW and use the reference brake force specified. If the technical GVW is between 2 specified weight values, choose the chapter with the highest closest weight value.

The gross vehicle weights in this document is valid for in regards to vehicle type described in each heading. The maximum technical GVW (Gross vehicle weight) was used to calculate the reference brake forces. The reference brake forces are calculated according to ISO 21995-2008.

The values in the tables correspond to a deceleration of 50 % (% of g). In tables stated as  $Z=0.5$ , a proportion to acceleration due to gravity.





EBS

# EBS

## EBS Disc brake 4x2

Applies to vehicles with maximum total weight of 20 tonnes.

**Z=0,5**

Axle	Reference braking force per axle (N) at brake pressure (bar)															
	0,5	1	1,5	2	2,5	3	3,5	4	4,5	5	5,5	6	6,5	7	7,5	8
Front axle	738	4430	8121	11813	15504	19196	22887	26579	30270	33962	37653	41345	45036	48728	52419	56111
Driving axle	552	3315	6077	8840	11602	14365	17127	19890	22652	25415	28177	30939	33702	36464	39227	41989

## EBS Disc brake 4x2

Applies to vehicles with maximum total weight of 25 tonnes.

**Z=0,5**

Axle	Reference braking force per axle (N) at brake pressure (bar)															
	0,5	1	1,5	2	2,5	3	3,5	4	4,5	5	5,5	6	6,5	7	7,5	8
Front axle	932	5589	10247	14905	19563	24221	28878	33536	38194	42852	47510	52167	56825	61483	66141	70799
Driving axle	697	4183	7668	11154	14639	18125	21611	25096	28582	32067	35553	39038	42524	46010	49495	52981



## EBS Disc brake 6x2, 6x2\*4, 6x2/2, 6x2/4

Applies to vehicles with maximum total weight of 31 tonnes.

**Z=0,5**

Axle	Reference braking force per axle (N) at brake pressure (bar)															
	0,5	1	1,5	2	2,5	3	3,5	4	4,5	5	5,5	6	6,5	7	7,5	8
Front axle	826	4957	9089	13220	17351	21482	25613	29744	33876	38007	42138	46269	50400	54531	58663	62794
Driving axle and tag axle	618	3710	6801	9893	12984	16076	19167	22259	25350	28442	31533	34624	37716	40807	43899	46990

## EBS Disc brake 6x2/2 MLA3

Applies to vehicles with maximum total weight of 28 tonnes.

**Z=0,5**

Axle	Reference braking force per axle (N) at brake pressure (bar)															
	0,5	1	1,5	2	2,5	3	3,5	4	4,5	5	5,5	6	6,5	7	7,5	8
Front axle	815	4891	8967	13042	17118	21194	25269	29345	33421	37496	41572	45648	49723	53799	57875	61951
Tag axle	382	2292	4202	6112	8021	9931	11841	13751	15661	17571	19481	21391	23300	25210	27120	29030
Driving axle	610	3660	6710	9760	12810	15860	18910	21960	25010	28060	31110	34160	37209	40259	43309	46359



## EBS Disc brake 6x4

Applies to vehicles with maximum total weight of 36 tonnes.

**Z=0,5**

Axle	Reference braking force per axle (N) at brake pressure (bar)															
	0,5	1	1,5	2	2,5	3	3,5	4	4,5	5	5,5	6	6,5	7	7,5	8
Front axle	932	5589	10247	14905	19563	24221	28878	33536	38194	42852	47510	52167	56825	61483	66141	70799
Driving axle	697	4183	7668	11154	14639	18125	21611	25096	28582	32067	35553	39038	42524	46010	49495	52981

## EBS Disc brake 8x2, 8x2\*6

Applies to vehicles with maximum total weight of 41 tonnes.

**Z=0,5**

Axle	Reference braking force per axle (N) at brake pressure (bar)															
	0,5	1	1,5	2	2,5	3	3,5	4	4,5	5	5,5	6	6,5	7	7,5	8
Front axle	826	4957	9089	13220	17351	21482	25613	29744	33876	38007	42138	46269	50400	54531	58663	62794
2:nd front axle, driving axle and tag axle	618	3710	6801	9893	12984	16076	19167	22259	25350	28442	31533	34624	37716	40807	43899	46990



## EBS Disc brake 8x2/4, 8x2/\*6

Applies to vehicles with maximum total weight of 41,5 tonnes.

**Z=0,5**

Axle	Reference braking force per axle (N) at brake pressure (bar)															
	0,5	1	1,5	2	2,5	3	3,5	4	4,5	5	5,5	6	6,5	7	7,5	8
Front axle	826	4957	9089	13220	17351	21482	25613	29744	33876	38007	42138	46269	50400	54531	58663	62794
2:nd front axle, driving axle and tag axle	618	3710	6801	9893	12984	16076	19167	22259	25350	28442	31533	34624	37716	40807	43899	46990

## EBS Disc brake 8x4\*4

Applies to vehicles with maximum total weight of 40 tonnes.

**Z=0,5**

Axle	Reference braking force per axle (N) at brake pressure (bar)															
	0,5	1	1,5	2	2,5	3	3,5	4	4,5	5	5,5	6	6,5	7	7,5	8
Front axle	826	4957	9089	13220	17351	21482	25613	29744	33876	38007	42138	46269	50400	54531	58663	62794
2:nd front axle, driving axle and tag axle	618	3710	6801	9893	12984	16076	19167	22259	25350	28442	31533	34624	37716	40807	43899	46990



## EBS Disc brake 8x4, 8x4/4

Applies to vehicles with maximum total weight of 46 tonnes.

**Z=0,5**

Axle	Reference braking force per axle (N) at brake pressure (bar)															
	0,5	1	1,5	2	2,5	3	3,5	4	4,5	5	5,5	6	6,5	7	7,5	8
Front axle	932	5589	10247	14905	19563	24221	28878	33536	38194	42852	47510	52167	56825	61483	66141	70799
2:nd front axle, driving axle and tag axle	697	4183	7668	11154	14639	18125	21611	25096	28582	32067	35553	39038	42524	46010	49495	52981

## EBS Disc brake 10x4\*6

Applies to vehicles with maximum total weight of 55 tonnes.

**Z=0,5**

Axle	Reference braking force per axle (N) at brake pressure (bar)															
	0,5	1	1,5	2	2,5	3	3,5	4	4,5	5	5,5	6	6,5	7	7,5	8
Front axle	938	5629	10319	15010	19700	24391	29081	33771	38462	43152	47843	52533	57224	61914	66605	71295
2:nd front axle and driving axle	702	4212	7722	11232	14742	18252	21762	25272	28782	32292	35802	39312	42822	46332	49842	53352
Tag axle	506	3033	5561	8089	10617	13145	15672	18200	20728	23256	25784	28312	30839	33367	35895	38423



## EBS Disc brake 10x4\*6

Applies to vehicles with maximum total weight of 46 tonnes.

**Z=0,5**

Axle	Reference braking force per axle (N) at brake pressure (bar)															
	0,5	1	1,5	2	2,5	3	3,5	4	4,5	5	5,5	6	6,5	7	7,5	8
Front axle	785	4708	8630	12553	16476	20399	24322	28245	32168	36091	40014	43937	47860	51783	55706	59629
2:nd front axle and driving axle	587	3523	6458	9394	12330	15265	18201	21137	24072	27008	29944	32879	35815	38751	41686	44622
Tag axle	423	2537	4651	6765	8880	10994	13108	15222	17336	19450	21565	23679	25793	27907	30021	32135

## EBS Drum brake 4x2

Applies to vehicles with maximum total weight of 22 tonnes.

**Z = 0.5**

Axle	Reference braking force per axle (N) at brake pressure (bar)															
	0,5	1	1,5	2	2,5	3	3,5	4	4,5	5	5,5	6	6,5	7	7,5	8
Front axle and driving axle	710	4260	7809	11359	14909	18458	22008	25558	29107	32657	36207	39756	43306	46856	50405	53955



## EBS Drum brake 4x2

Applies to vehicles with maximum total weight of 25 tonnes.

**Z = 0.5**

Axle	Reference braking force per axle (N) at brake pressure (bar)															
	0,5	1	1,5	2	2,5	3	3,5	4	4,5	5	5,5	6	6,5	7	7,5	8
Front axle and driving axle	807	4840	8874	12908	16942	20975	25009	29043	33076	37110	41144	45178	49211	53245	57279	61313

## EBS Drum brake 6x2Z

Applies to vehicles with maximum total weight of 31 tonnes.

**Z = 0.5**

Axle	Reference braking force per axle (N) at brake pressure (bar)															
	0,5	1	1,5	2	2,5	3	3,5	4	4,5	5	5,5	6	6,5	7	7,5	8
Front axle and driving axle	783	4696	8609	12523	16436	20349	24263	28176	32089	36002	39916	43829	47742	51656	55569	59482
Tag axle	0	1999	4220	6440	8661	10882	13103	15324	17545	19765	21986	24207	26428	28649	30870	33090



## EBS Drum brake 6x2, 6x4

Applies to vehicles with maximum total weight of 31 tonnes.

**Z = 0.5**

Axle	Reference braking force per axle (N) at brake pressure (bar)															
	0,5	1	1,5	2	2,5	3	3,5	4	4,5	5	5,5	6	6,5	7	7,5	8
Front axle, driving axle and tag axle	667	4001	7336	10671	14005	17340	20674	24009	27343	30678	34012	37347	40681	44016	47350	50685

## EBS Drum brake 6x4

Applies to vehicles with maximum total weight of 36 tonnes.

**Z = 0.5**

Axle	Reference braking force per axle (N) at brake pressure (bar)															
	0,5	1	1,5	2	2,5	3	3,5	4	4,5	5	5,5	6	6,5	7	7,5	8
Front axle and driving axle	774	4647	8519	12392	16264	20136	24009	27881	31753	35626	39498	43371	47243	51115	54988	58860





## EBS Drum brake 6x4

Applies to vehicles with maximum total weight of 42 tonnes.

**Z = 0.5**

Axle	Reference braking force per axle (N) at brake pressure (bar)															
	0,5	1	1,5	2	2,5	3	3,5	4	4,5	5	5,5	6	6,5	7	7,5	8
Front axle and driving axle	904	5421	9939	14457	18975	23492	28010	32528	37046	41563	46081	50559	55117	59634	64152	68670



ABS

# ABS

## ABS Drum brake 4x2, 4x4

Applies to vehicles with a maximum total weight of 20 tonnes with brake chamber size 20-20 or 24-24.

**Z = 0.5**

Axle	Reference braking force per axle (N) at brake pressure (bar)															
	0,5	1	1,5	2	2,5	3	3,5	4	4,5	5	5,5	6	6,5	7	7,5	8
Front axle and driving axle	658	3947	7237	10526	13816	17105	20395	23684	26974	30263	33553	36842	40132	43421	46711	50000

## ABS Drum brake 4x2, 4x4

Applies to vehicles with a maximum total weight of 20 tonnes with brake chamber size 16-20, 20-24 or 24-30.

**Z = 0.5**

Axle	Reference braking force per axle (N) at brake pressure (bar)															
	0,5	1	1,5	2	2,5	3	3,5	4	4,5	5	5,5	6	6,5	7	7,5	8
Front axle	590	3539	6488	9437	12387	15336	18285	21234	24183	27132	30082	33031	35980	38929	41878	44828
Driving axle	726	4356	7985	11615	15245	18875	22505	26134	29764	33394	37024	40653	44283	47913	51543	55172



## ABS Drum brake 4x2, 4x4

Applies to vehicles with a maximum total weight of 25 tonnes with brake chamber size 24-24 or 30-30.

**Z = 0.5**

Axle	Reference braking force per axle (N) at brake pressure (bar)															
	0,5	1	1,5	2	2,5	3	3,5	4	4,5	5	5,5	6	6,5	7	7,5	8
Front axle and driving axle	822	4934	9046	13158	17270	21382	25493	29605	33717	37829	41941	46053	50164	54276	58338	62500

## ABS Drum brake 4x2, 4x4

Applies to vehicles with a maximum total weight of 25 tonnes with brake chamber size 24-30.

**Z = 0.5**

Axle	Reference braking force per axle (N) at brake pressure (bar)															
	0,5	1	1,5	2	2,5	3	3,5	4	4,5	5	5,5	6	6,5	7	7,5	8
Front axle	702	4211	7719	11228	14737	18246	21754	25263	28772	32281	35789	39298	42807	46316	49825	53333
Driving axle	943	5658	15088	19803	24518	29232	33947	38662	43377	43377	48092	52807	57522	62237	66952	71667



## ABS Drum brake 6x2A/B, 6x4\*4, 6x4, 6x6

Applies to vehicles with a maximum total weight of 28 tonnes with brake chamber size 20-20-20 or 24-24-24.

**Z = 0.5**

Axle	Reference braking force per axle (N) at brake pressure (bar)															
	0,5	1	1,5	2	2,5	3	3,5	4	4,5	5	5,5	6	6,5	7	7,5	8
Front axle driving axle and tag axle	614	3684	6754	9825	12895	15965	19035	22105	25175	28246	31316	34386	37456	40526	43596	46667

## ABS Drum brake 6x2A/B, 6x4\*4, 6x4, 6x6

Applies to vehicles with a maximum total weight of 28 tonnes with brake chamber size 16-20-20, 20-24-24 or 24-30-30.

**Z = 0.5**

Axle	Reference braking force per axle (N) at brake pressure (bar)															
	0,5	1	1,5	2	2,5	3	3,5	4	4,5	5	5,5	6	6,5	7	7,5	8
Front axle	532	3195	5854	8515	11175	13836	16497	19158	21819	24480	27140	29801	32462	35123	37784	40444
Driving axle and tag axle	655	3930	7205	10480	13754	17029	20304	23579	26854	30129	33404	36678	39953	43228	46503	49778



## ABS Drum brake 6x2A/B, 6x4\*4

Applies to vehicles with a maximum total weight of 28 tonnes with brake chamber size 20-20-16, 24-24-16 or 24-24-20.

**Z = 0.5**

Axle	Reference braking force per axle (N) at brake pressure (bar)															
	0,5	1	1,5	2	2,5	3	3,5	4	4,5	5	5,5	6	6,5	7	7,5	8
Front axle and driving axle	655	3930	7205	10480	13754	17029	20304	23579	26854	30129	33404	36678	39953	43228	46503	49778
Tag axle	532	3193	5854	8515	11175	13836	16497	19158	21819	24480	27140	29801	32462	35123	38778	40444

## ABS Drum brake 6x2A/B, 6x4\*4

Applies to vehicles with a maximum total weight of 28 tonnes with brake chamber size 20-24-16 or 20-24-20.

**Z = 0.5**

Axle	Reference braking force per axle (N) at brake pressure (bar)															
	0,5	1	1,5	2	2,5	3	3,5	4	4,5	5	5,5	6	6,5	7	7,5	8
Front axle	599	3592	6586	9579	12572	15566	18559	21553	24546	27539	30533	33526	36520	39513	42507	45500
Driving axle	737	4421	8105	11789	15474	19158	22842	26526	30211	33895	37579	41263	44947	48632	52316	56000
Tag axle	507	3039	5572	8105	10638	13171	15704	18237	20770	23303	25836	28368	30901	33434	35967	38500



## ABS Drum brake 6x2A/B, 6x4\*4, 6x4, 6x6

Applies to vehicles with a maximum total weight of 31 tonnes with brake chamber size 20-20-20 or 24-24-24.

**Z = 0.5**

Axle	Reference braking force per axle (N) at brake pressure (bar)															
	0,5	1	1,5	2	2,5	3	3,5	4	4,5	5	5,5	6	6,5	7	7,5	8
Front axle driving axle and tag axle	680	4079	7478	10877	14276	17675	21075	24474	27873	31272	34671	38070	41469	44868	48268	51667

## ABS Drum brake 6x2A/B, 6x4\*4, 6x4, 6x6

Applies to vehicles with a maximum total weight of 31 tonnes with brake chamber size 20-24-24 or 24-30-30.

**Z = 0.5**

Axle	Reference braking force per axle (N) at brake pressure (bar)															
	0,5	1	1,5	2	2,5	3	3,5	4	4,5	5	5,5	6	6,5	7	7,5	8
Front axle	589	3535	6481	9427	12373	15319	18265	21211	24156	27102	30048	32994	35940	38886	41832	44778
Driving axle and tag axle	725	4351	7977	11602	15228	18854	22480	26105	29731	33357	36982	40608	44234	47860	51485	55111



## ABS Drum brake 6x2A/B, 6x4\*4

Applies to vehicles with a maximum total weight of 31 tonnes with brake chamber size 24-24-16 or 24-24-20.

**Z = 0.5**

Axle	Reference braking force per axle (N) at brake pressure (bar)															
	0,5	1	1,5	2	2,5	3	3,5	4	4,5	5	5,5	6	6,5	7	7,5	8
Front axle and driving axle	725	4351	7977	11602	15228	18854	22480	26105	29731	33357	36982	40608	44234	47860	51485	55111
Tag axle	589	3535	6481	9427	12373	15319	18265	21211	24156	27102	30048	32994	35940	38886	41832	44778

## ABS Drum brake 6x2A/B, 6x4\*4

Applies to vehicles with a maximum total weight of 31 tonnes with brake chamber size 20-24-16 or 20-24-20.

**Z = 0.5**

Axle	Reference braking force per axle (N) at brake pressure (bar)															
	0,5	1	1,5	2	2,5	3	3,5	4	4,5	5	5,5	6	6,5	7	7,5	8
Front axle	663	3977	7291	10605	13919	17234	20548	23862	27176	30490	33804	37118	40433	43747	47061	50375
Driving axle	816	4895	8974	13053	17132	21211	25289	29368	33447	37526	41605	45684	49763	53842	57921	62000
Tag axle	561	3365	6169	8974	11778	14582	17387	20191	22995	25799	28604	31408	34212	37016	39821	42625



## ABS Drum brake 6x4, 6x6

Applies to vehicles with a maximum total weight of 36 tonnes with brake chamber size 24-24-24 or 30-30-30.

**Z=0.5**

Axle	Reference braking force per axle (N) at brake pressure (bar)															
	0,5	1	1,5	2	2,5	3	3,5	4	4,5	5	5,5	6	6,5	7	7,5	8
Front axle and driving axle	789	4737	8684	12632	16579	20526	24474	28421	32368	36316	40263	44211	48158	52105	56053	60000

## ABS Drum brake 6x4, 6x6

Applies to vehicles with a maximum total weight of 36 tonnes with brake chamber size 20-24-24 or 24-30-30.

**Z=0.5**

Axle	Reference braking force per axle (N) at brake pressure (bar)															
	0,5	1	1,5	2	2,5	3	3,5	4	4,5	5	5,5	6	6,5	7	7,5	8
Front axle	684	4105	7526	10974	14368	17789	21211	24632	28053	31474	34895	38316	41737	45158	48579	52000
Driving axle	842	5053	9263	13474	17684	21895	26105	30316	34526	38737	42947	47158	51368	55579	59789	64000





## ABS Drum brake 6x4, 6x6

Applies to vehicles with a maximum total weight of 42 tonnes with brake chamber size 24-24-24 or 30-30-30.

**Z=0.5**

Axle	Reference braking force per axle (N) at brake pressure (bar)															
	0,5	1	1,5	2	2,5	3	3,5	4	4,5	5	5,5	6	6,5	7	7,5	8
Front axle and driving axle	921	5526	10132	14737	19342	23947	28553	33158	37763	42368	46974	51579	56184	60789	65395	7000

## ABS Drum brake 6x4, 6x6

Applies to vehicles with a maximum total weight of 42 tonnes with brake chamber size 24-30-30.

**Z=0.5**

Axle	Reference braking force per axle (N) at brake pressure (bar)															
	0,5	1	1,5	2	2,5	3	3,5	4	4,5	5	5,5	6	6,5	7	7,5	8
Front axle	749	4496	8243	11989	15736	19483	23229	26976	30723	34469	38216	41963	45709	49456	53202	56949
Driving axle	1007	6041	11076	16111	21145	26180	31214	36249	41283	46318	51353	56387	61422	66456	71491	76525



## ABS Drum brake 6x2Z

Applies to vehicles with a maximum total weight of 28 tonnes with brake chamber size 20-24-16.

**Z = 0.5**

Axle	Reference braking force per axle (N) at brake pressure (bar)															
	0,5	1	1,5	2	2,5	3	3,5	4	4,5	5	5,5	6	6,5	7	7,5	8
Front axle	636	3815	6993	10172	13351	16530	19709	22888	26067	29245	32424	25603	38782	41961	45140	48319
Driving axle	782	4695	8607	12520	16432	20345	24257	28170	32082	35994	39907	43819	47732	51644	55557	59469
Tag axle	0	1741	3918	6094	8271	10447	12624	14800	16977	19153	21330	23506	25683	27859	30036	32212

## ABS Drum brake 6x2Z

Applies to vehicles with a maximum total weight of 28 tonnes with brake chamber size 24-24-16.

**Z = 0.5**

Axle	Reference braking force per axle (N) at brake pressure (bar)															
	0,5	1	1,5	2	2,5	3	3,5	4	4,5	5	5,5	6	6,5	7	7,5	8
Front axle and driving axle	725	4349	7972	11596	15220	18844	22468	26091	29715	33339	36963	40587	44211	47834	51458	55082
Tag axle	0	1613	3629	5645	7661	9677	11693	13708	15724	17740	19756	21772	23788	25804	27820	29836



## ABS Drum brake 6x2Z

Applies to vehicles with a maximum total weight of 31 tonnes with brake chamber size 20-24-16.

**Z = 0.5**

Axle	Reference braking force per axle (N) at brake pressure (bar)															
	0,5	1	1,5	2	2,5	3	3,5	4	4,5	5	5,5	6	6,5	7	7,5	8
Front axle	704	4223	7743	11262	14782	18301	21821	25340	28859	32379	35898	39818	42937	46457	49976	53496
Driving axle	866	5198	9530	13861	18193	22524	26856	31188	35519	39851	44183	48514	52846	57177	61509	65841
Tag axle	0	1928	4337	6747	9157	11567	13976	16386	18796	21205	23615	26025	28435	30844	33254	35664

## ABS Drum brake 6x2Z

Applies to vehicles with a maximum total weight of 31 tonnes with brake chamber size 24-24-16.

**Z = 0.5**

Axle	Reference braking force per axle (N) at brake pressure (bar)															
	0,5	1	1,5	2	2,5	3	3,5	4	4,5	5	5,5	6	6,5	7	7,5	8
Front axle and driving axle	802	4814	8827	12839	16851	20863	24875	28887	32899	36911	40923	44935	48947	52959	56972	60984
Tag axle	0	1786	4018	6249	8481	10713	12945	15177	17409	19641	21873	24105	26337	28569	30801	33033



## ABS Drum brake 8x2A/B, 8x4, 8x6, 8x8

Applies to vehicles with a maximum total weight of 35 tonnes with brake chamber size 20-20-20-20 or 24-24-24-24.

**Z = 0.5**

Axle	Reference braking force per axle (N) at brake pressure (bar)															
	0,5	1	1,5	2	2,5	3	3,5	4	4,5	5	5,5	6	6,5	7	7,5	8
Front axle driving axle and tag axle	576	3454	6332	9211	12089	14967	17845	20724	23602	26480	29359	32237	35115	37993	40872	43750

## ABS Drum brake 8x2A/B, 8x4, 8x6, 8x8

Applies to vehicles with a maximum total weight of 35 tonnes with brake chamber size 16-16-20-20 or 20-20-24-24.

**Z = 0.5**

Axle	Reference braking force per axle (N) at brake pressure (bar)															
	0,5	1	1,5	2	2,5	3	3,5	4	4,5	5	5,5	6	6,5	7	7,5	8
Front axle	516	3097	5677	8258	10838	13419	15999	18580	21160	23741	26321	28902	31483	34063	36644	39224
Driving axle and tag axle	635	3811	6987	10163	13339	16515	19691	22868	26044	29220	32396	35572	38748	41924	45100	48276



## ABS Drum brake 8x2A/B

Applies to vehicles with a maximum total weight of 35 tonnes with brake chamber size 20-20-24-20.

**Z = 0.5**

Axle	Reference braking force per axle (N) at brake pressure (bar)															
	0,5	1	1,5	2	2,5	3	3,5	4	4,5	5	5,5	6	6,5	7	7,5	8
Front axle and tag axle	544	3266	5987	8708	11429	14151	16872	19593	22315	25036	27757	30478	33200	35921	38642	41364
Driving axle	670	4019	7368	10718	14067	17416	20766	24115	27464	30813	34163	37512	40861	44211	47560	50909

## ABS Drum brake 8x2A/B, 8x4, 8x6, 8x8, 8x4/4

Applies to vehicles with a maximum total weight of 41 tonnes with brake chamber size 20-20-20-20, 24-24-24-24 or 30-30-30-30.

**Z = 0.5**

Axle	Reference braking force per axle (N) at brake pressure (bar)															
	0,5	1	1,5	2	2,5	3	3,5	4	4,5	5	5,5	6	6,5	7	7,5	8
Front axle, driving axle and tag axle	674	4046	7418	10789	14161	17533	20905	24276	27648	31020	34391	37763	41135	44507	47878	51250



## ABS Drum brake 8x2A/B, 8x4, 8x6, 8x8

Applies to vehicles with a maximum total weight of 41 tonnes with brake chamber size 20-20-24-24 or 24-24-30-30.

**Z = 0.5**

Axle	Reference braking force per axle (N) at brake pressure (bar)															
	0,5	1	1,5	2	2,5	3	3,5	4	4,5	5	5,5	6	6,5	7	7,5	8
Front axle	605	3627	6650	9673	12696	15719	18742	21765	24788	27811	30834	33857	36880	39902	42925	45948
Driving axle and tag axle	744	4465	8185	11906	15626	19347	23067	26788	30508	34229	37949	41670	45390	49111	52831	56552

## ABS Drum brake 8x2A/B

Applies to vehicles with a maximum total weight of 41 tonnes with brake chamber size 20-20-24-20.

**Z = 0.5**

Axle	Reference braking force per axle (N) at brake pressure (bar)															
	0,5	1	1,5	2	2,5	3	3,5	4	4,5	5	5,5	6	6,5	7	7,5	8
Front axle and tag axle	638	3825	7013	10201	13389	16577	19764	22952	26140	29328	32516	35703	38891	42079	45267	48455
Driving axle	785	4708	8632	12555	16478	20402	24325	28249	32172	36096	40019	43943	47866	51789	55713	59636



## ABS Drum brake 8x4, 8x6, 8x8, 8x4/4

Applies to vehicles with a maximum total weight of 46 tonnes with brake chamber size 24-24-24-24 or 30-30-30-30.

**Z = 0.5**

Axle	Reference braking force per axle (N) at brake pressure (bar)															
	0,5	1	1,5	2	2,5	3	3,5	4	4,5	5	5,5	6	6,5	7	7,5	8
Front axle and driving axle	757	4539	8322	12105	15888	19671	23454	27237	31020	34803	38586	42368	46151	49934	53717	57500

## ABS Drum brake 8x4, 8x6, 8x8

Applies to vehicles with a maximum total weight of 46 tonnes with brake chamber size 20-20-24-24 or 24-24-30-30.

**Z = 0.5**

Axle	Reference braking force per axle (N) at brake pressure (bar)															
	0,5	1	1,5	2	2,5	3	3,5	4	4,5	5	5,5	6	6,5	7	7,5	8
Front axle	678	4070	7461	10853	14245	17636	21028	24419	27811	31202	34594	37985	41377	44769	48160	51552
Driving axle	835	5009	9183	13358	17532	21706	25880	30054	34229	38403	42577	46751	50926	55100	59274	63448



## ABS Drum brake 8x4, 8x6, 8x8, 8x4/4

Applies to vehicles with a maximum total weight of 52 tonnes with brake chamber size 24-24-24-24 or 30-30-30-30.

**Z = 0.5**

Axle	Reference braking force per axle (N) at brake pressure (bar)															
	0,5	1	1,5	2	2,5	3	3,5	4	4,5	5	5,5	6	6,5	7	7,5	8
Front axle, driving axle and tag axle	855	5132	9408	13684	17961	22237	26513	30789	35066	39342	43618	47895	52171	56447	60724	65000

## ABS Drum brake 8x4, 8x6, 8x8

Applies to vehicles with a maximum total weight of 46 tonnes with brake chamber size 24-24-30-30.

**Z = 0.5**

Axle	Reference braking force per axle (N) at brake pressure (bar)															
	0,5	1	1,5	2	2,5	3	3,5	4	4,5	5	5,5	6	6,5	7	7,5	8
Front axle	730	4379	8028	11677	15326	18975	22625	26274	29923	33572	37221	40870	44519	48168	51818	55467
Driving axle	981	5884	10788	15691	20595	25498	30402	35305	40209	45112	50016	54919	59823	64726	69630	74533





## ABS Drum brake 8x2Z

Applies to vehicles with a maximum total weight of 35 tonnes with brake chamber size 20-20-24-16.

**Z = 0.5**

Axle	Reference braking force per axle (N) at brake pressure (bar)															
	0,5	1	1,5	2	2,5	3	3,5	4	4,5	5	5,5	6	6,5	7	7,5	8
Front axle	591	3545	6499	9453	12407	15361	18315	21269	24223	27177	30131	33085	36039	38993	41947	44901
Driving axle	727	4363	7999	11634	15270	18906	22542	26177	29813	33449	37084	40720	44356	47992	51627	55263
Tag axle	0	1618	3641	5663	7686	9708	11731	13754	15776	17799	19821	21844	23866	25889	27912	29934

## ABS Drum brake 8x2Z

Applies to vehicles with a maximum total weight of 35 tonnes with brake chamber size 24-24-24-16.

**Z = 0.5**

Axle	Reference braking force per axle (N) at brake pressure (bar)															
	0,5	1	1,5	2	2,5	3	3,5	4	4,5	5	5,5	6	6,5	7	7,5	8
Front axle and driving axle	650	3901	7152	10402	13653	16904	20155	23406	26656	29907	33158	36409	39659	42910	46161	49412
Tag axle	0	1447	2355	5064	6872	8680	10489	12297	14106	15914	17723	19531	21339	23148	24956	26765



## ABS Drum brake 8x2Z

Applies to vehicles with a maximum total weight of 41 tonnes with brake chamber size 20-20-24-16.

**Z = 0.5**

Axle	Reference braking force per axle (N) at brake pressure (bar)															
	0,5	1	1,5	2	2,5	3	3,5	4	4,5	5	5,5	6	6,5	7	7,5	8
Front axle	692	4153	7613	11073	14534	17994	21455	24915	28376	31836	35296	38757	42217	45678	49138	52599
Driving axle	852	5111	9370	13629	17888	22147	26406	30665	34924	39183	43442	47701	51960	56219	60478	64737
Tag axle	0	1895	4265	6634	9003	11373	13742	16111	18481	20850	23219	25589	27958	30327	32696	35066

## ABS Drum brake 8x2Z

Applies to vehicles with a maximum total weight of 41 tonnes with brake chamber size 24-24-24-16.

**Z = 0.5**

Axle	Reference braking force per axle (N) at brake pressure (bar)															
	0,5	1	1,5	2	2,5	3	3,5	4	4,5	5	5,5	6	6,5	7	7,5	8
Front axle and driving axle	762	4570	8378	12186	15994	19802	23610	27418	31226	35034	38842	42650	46458	50266	54074	57882
Tag axle	0	1695	3813	5932	8050	10169	12287	14405	16524	18642	20761	22879	24998	27116	29234	31353



## ABS Drum brake 8x4\*4

Applies to vehicles with a maximum total weight of 38 tonnes with brake chamber size 24-24-24-16.

**Z = 0.5**

Axle	Reference braking force per axle (N) at brake pressure (bar)															
	0,5	1	1,5	2	2,5	3	3,5	4	4,5	5	5,5	6	6,5	7	7,5	8
Front axle and driving axle	678	4068	7458	10847	14237	17627	21017	24407	27797	31186	34576	37966	41356	44746	48136	51525
Tag axle	466	2797	5127	7458	9788	12119	14449	16780	19110	21441	23771	26102	28432	30763	33093	35424

## ABS Drum brake 10x4\*6

Applies to vehicles with a maximum total weight of 40 tonnes with brake chamber size 24-24-24-24-16 or 30-30-30-30-20.

**Z = 0.5**

Axle	Reference braking force per axle (N) at brake pressure (bar)															
	0,5	1	1,5	2	2,5	3	3,5	4	4,5	5	5,5	6	6,5	7	7,5	8
Front axle and driving axle	600	3600	6601	9601	12602	15602	18602	21603	24603	27604	30604	33604	36605	39605	42606	45606
Tag axle	363	2177	3991	5805	7620	9434	11248	13062	14876	16691	18505	20319	22133	23947	25762	27576



## ABS Drum brake 10x4\*6

Applies to vehicles with a maximum total weight of 50 tonnes with brake chamber size 24-24-24-24-16 or 30-30-30-30-20.

**Z = 0.5**

Axle	Reference braking force per axle (N) at brake pressure (bar)															
	0,5	1	1,5	2	2,5	3	3,5	4	4,5	5	5,5	6	6,5	7	7,5	8
Front axle and driving axle	714	4286	7858	11430	15002	18574	22146	25718	29290	32862	36433	40005	43577	47149	50721	54293
Tag axle	432	2592	4751	6911	9071	11231	13390	15550	17710	19870	22030	24189	26349	28509	30669	32828

## ABS Drum brake 10x4\*6

Applies to vehicles with a maximum total weight of 59 tonnes with brake chamber size 30-30-30-30-20.

**Z = 0.5**

Axle	Reference braking force per axle (N) at brake pressure (bar)															
	0,5	1	1,5	2	2,5	3	3,5	4	4,5	5	5,5	6	6,5	7	7,5	8
Front axle and driving axle	843	5058	9273	13488	17702	21917	26132	30347	34562	38777	42991	47206	51421	55636	59851	64066
Tag axle	510	3058	5607	8155	10704	13252	15801	18349	20898	23446	25995	28543	31092	33640	36189	38737